

# PROVOX<sup>®</sup> Vega<sup>™</sup>

辅助发音管  
穿刺套装 (含普通辅助发音管)



Rx  
ONLY



CE 0413



STERILE EO



42 °C  
108 °F  
RT  
2 °C  
36 °F

## Figures 图示

### 1. Provox Vega Voice Prosthesis 辅助发音管

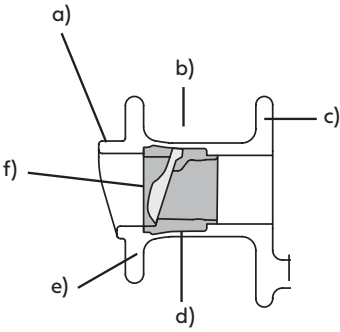

- a) Prosthesis Hood 辅助发音管罩
- b) Prosthesis Shaft 辅助发音管轴
- c) Tracheal Flange 气管侧轮缘
- d) Radio-opaque fluoroplastic Valve Seat 不透射线氟塑料阀座
- e) Esophageal Flange 食管侧轮缘
- f) Valve Flap 阀瓣

### 2. Tracheo-esophageal speech 气管食管发音

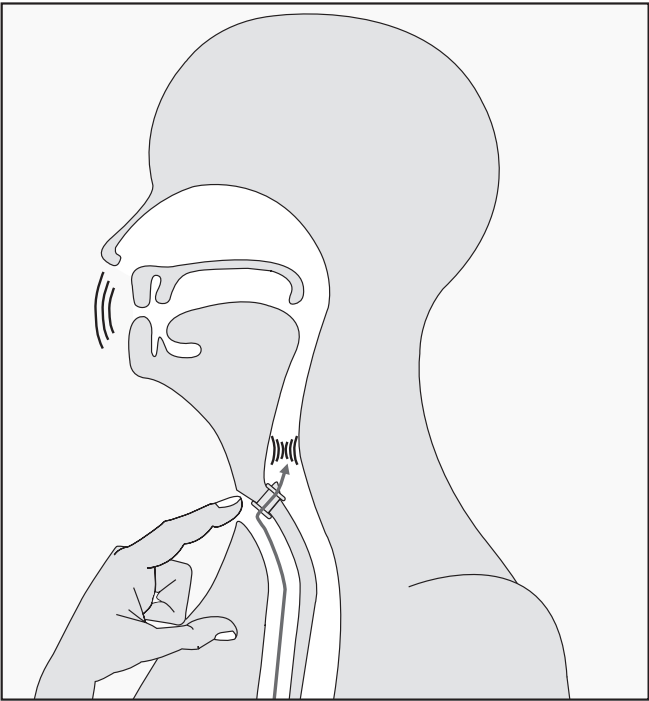

### 3. Provox Brush 清洁刷

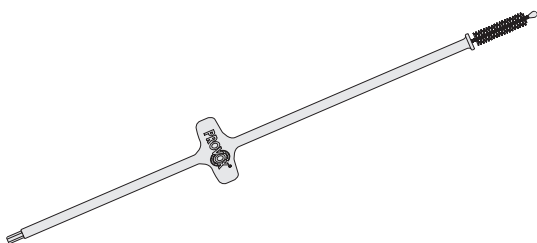

### 4. Provox Flush 冲洗器

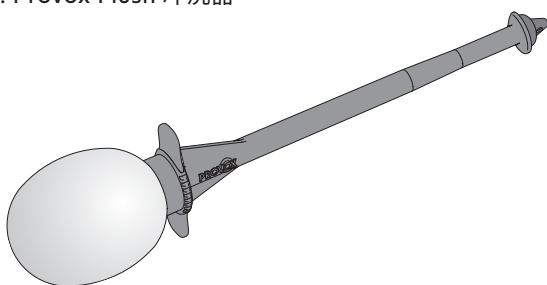

### 5. Provox Vega Plug 塞子

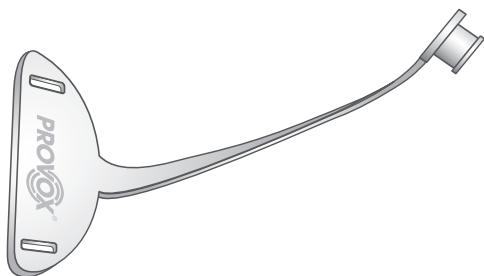

## **Disclaimer**

Atos Medical offers no warranty - neither expressed nor implied - to the purchaser hereunder as to the lifetime of the product delivered, which may vary with individual use and biological conditions. Furthermore, Atos Medical offers no warranty of merchantability or fitness of the product for any particular purpose.

Due to local Chinese requirements, the text in the Intended use paragraph and the Overall description and product composition paragraph are not translated verbatim.

## **免责声明**

欧拓适医疗有限责任公司不向买方提供本协议项下所交付产品的使用期限的任何保证——无论是明示的还是默示的——使用期限可能因个人使用情况和生物条件的不同而有所不同，此外，欧拓适医疗有限责任公司不保证产品的适销性或适合于任何特定用途。

## Contents

ENGLISH .....	6
简体中文 .....	10

## Stomal airway management

### Emergency situations

It is important that emergency personnel knows that you are a neck breather. This will help them determining that oxygen and rescue breathing need to be administered to your stoma and not to your mouth or nose.

We recommend that you and your clinician download the guidelines for rescue breathing from [www.atosmedical.com/rescuebreathing](http://www.atosmedical.com/rescuebreathing)

### Elective situations

If you need to undergo a procedure that requires intubation (putting a breathing tube in your windpipe), it is very important that the anesthesiologist and the doctor who is performing the procedure are aware that you are a neck breather and that you are using a voice prosthesis. It is important for them to understand that the voice prosthesis should stay in place. If it is removed, fluids from your mouth, food pipe, or stomach may get into your windpipe.

It is very important that the intubation tube is inserted and removed carefully so that the voice prosthesis does not dislodge or come out.

## 1. Glossary

Clinician	Medical professional or properly licensed speech and language therapist / pathologist or clinical specialist nurse who is trained in voice rehabilitation procedures.
HME	Heat and Moisture Exchanger (Artificial Nose). Device that retains the heat and moisture in the exhaled air, which otherwise is lost when breathing through a tracheostoma.
PE-Segment	Pharyngo-esophageal segment. The part of the esophagus (food pipe) where sound is created by vibration of tissue when using a voice prosthesis.
Silicone	A material often used in medical devices.
TE-puncture	Small artificial opening created between the trachea (wind pipe) and the esophagus (food pipe).
Tracheostoma	Breathing opening in the front of the neck, where the windpipe is connected to the skin (also called 'stoma').
Voice prosthesis	A one-way valve with retaining flanges inserted into a TE-puncture to allow speech by redirecting air to the esophagus (food pipe) while reducing the risk of food and liquids entering the trachea (wind pipe).

## 2. Descriptive information

### 2.1 Intended Use

The Provox Vega Voice Prosthesis is a sterile single use indwelling voice prosthesis intended for voice rehabilitation after surgical removal of the larynx (laryngectomy). Cleaning of the voice prosthesis is performed by the patient while it remains in situ.

### 2.2 Overall description and product composition (结构及组成)

Provox Voice Prosthesis is composed of Silicone, Polyvinylidene Fluoride (PVDF) and Silicone adhesive.

The insertion system in the Provox Vega Puncture Set is composed of MethylMethacrylate Acrylonitrile Butadiene Styrene (MABS), Stainless steel, Polyamide (PA66) and epoxy glue, Thermoplastic Styrene-Ethylene/Butylene-Styrene (TPS-SEBS), polypropylene (PP), Polyvinylidene Fluoride (PVDF).

The insertion system in the Provox Vega and Provox Vega XtraSeal is composed of Polypropylene (PP), colorant, and Silicone oil.

Provox Flush in the Provox Accessories is composed of Silicone, Polypropylene (PP) and blue masterbatch; Provox Vega Plug in the Provox Accessories is made of Silicone.

Provox Voice Prosthesis and its set are sterilized by ethylene oxide. The product is for single use. The Provox accessories are non-sterile products.

The shelf life of package sterilization is 5 years.

### 2.3 Description of the device

Provox Vega is a single-use medical device with a one-way valve that keeps a TE-puncture open for speech, and reduces the risk of liquid and food entering the trachea. It is made of medical grade silicone and fluoroplastic.

For illustration see Fig. 1.

- Prosthesis Hood
- Prosthesis Shaft
- Tracheal Flange
- Radio-opaque fluoroplastic Valve Seat
- Esophageal Flange
- Valve Flap

### Provox Vega package

The Provox Vega package contains the following user accessories:

- 1 Provox Brush of a size corresponding to the voice prosthesis, non-sterile
- 1 Provox Brush Instructions for Use
- 1 Provox Vega Patient's manual

## 2.4 CONTRAINDICATIONS

There are no known contraindications for use or replacement of the Provox Vega voice prosthesis among patients already using prosthetic voice rehabilitation.

## 2.5 WARNINGS

**Accidental aspiration** (entering the windpipe) of the Provox Vega voice prosthesis or other components of the Provox voice rehabilitation system may occur. Immediate symptoms may include gagging, coughing, choking or wheezing. If this occurs **seek immediate medical treatment**. A foreign body in your airway may cause severe complications such as acute respiratory distress and/or respiratory arrest, and has to be removed by a clinician.

**Accidental swallowing** of the Provox Vega voice prosthesis may occur. If this occurs, contact your physician who will advise you further.

Re-use and re-processing may cause cross-contamination and damage to the device, which could cause patient harm.

## 2.6 PRECAUTIONS

### Consult your clinician if

- There is leakage through or around the prosthesis (coughing; and/or change of mucus color)
- Speaking becomes difficult (higher effort and/or voice sounds more strained)
- There are any signs of inflammation or tissue changes at the puncture region (pain, heat, swelling, traces of blood on the brush after brushing).

### To reduce infection risk:

Make sure that your hands are thoroughly clean and dry before using your hands in the area of your tracheostoma, and before cleaning your voice prosthesis and/or accessories.

Keep all devices clean that may enter or make any contact with your tracheostoma and voice prosthesis.

### To reduce risk of product damage:

Only use genuine Provox accessories that are intended for use with Provox Vega for the handling and cleaning of your prosthesis.

## 3. Instructions for use

### 3.1 Using the Provox Vega to speak

When you close off your tracheostoma, you can direct the air from your lungs through the prosthesis into your esophagus (Fig. 2).

That air stream causes vibration of the tissues in your esophagus, which produces the sound of your voice. You can speak by using a Heat and Moisture Exchanger like the Provox HME, using a handsfree speaking device like Provox Freehands HME or simply by closing your stoma directly with a finger.

An HME may improve pulmonary function and also facilitates stoma occlusion and speaking. A handsfree device enables speech without the need to close the tracheostoma by a finger.

### 3.2 Cleaning the Provox Vega

In order for you to speak with your voice prosthesis, the prosthesis needs to be clean so that air can pass through it. Regular cleaning of the prosthesis also helps to prolong device life.

- Brushing the prostheses with the Provox Brush twice a day removes mucus and food remnants from the prosthesis.
- Flushing the prosthesis with the Provox Flush also helps to clean debris and mucus from the prosthesis, which helps increase the life of the device.

**Note:** The Provox Flush is intended for use only by patients who have been assessed by the clinician to be able to consistently follow the instructions for use without clinician supervision.

- Some dietary measures, like the daily intake of yogurt or butter milk containing lactobacilli, are considered to be helpful against excessive Candida growth.

**CAUTION:** Only use genuine Provox accessories that are intended for use with Provox Vega when cleaning your prosthesis. Other devices may cause personal injury or damage to the voice prosthesis.

### 3.3 Accessories

**Provox Brush** is used by the patient to clean the inside of the prosthesis (Fig. 3).

**Provox Flush** is an additional cleaning device that allows flushing of the prosthesis (Fig. 4).

**Provox Vega Plug** is a First Aid tool for patient's use that temporarily blocks leakage through the prosthesis (Fig. 5).

### 3.4 Additional devices

**Provox HME:** Heat- and Moisture Exchanger partially restores lost nasal functions (heating, humidifying, breathing resistance).

**Provox FreeHands HME:** A Heat and Moisture Exchanger combined with an automatic tracheostoma valve, designed to allow hands-free speech.

**Provox LaryTube:** A silicone tracheal cannula intended to support shrinking stomas while retaining other rehabilitation devices of the Provox System.

**Provox LaryButton:** A soft, self-retaining silicone tracheal cannula intended to support shrinking stomas while retaining other rehabilitation devices of the Provox System.

## 4. Adverse events/ Trouble shooting by symptom

It is the responsibility of your clinician to inform you about risks and benefits of prosthetic voice rehabilitation and to instruct you what to do in case you may encounter adverse events. If you are not sure that you have completely understood all instructions, ask your clinician for further explanation.

**Symptom:** Coughing (triggered by drinking or eating) while the prosthesis is in place.

**Most common reasons:** Leakage through or around the prosthesis.

**Measures:**

1. Clean the prosthesis with the Provox Brush and/or Flush. There may be food remnants preventing the valve from proper closure.

**If leakage continues:**

2. Observe the prosthesis while drinking. Try to identify if it leaks through the center or around the prosthesis.
  - a.) If you think it leaks through the center you can use the Provox Vega Plug while you are eating and drinking to prevent leakage. Notify your clinician that you need a new prosthesis.
  - b.) If you think it leaks around, or if the Plug does not stop the leakage. Notify your clinician that you may have leakage around your prosthesis.

**Symptom:** Speaking becomes more and more difficult.

**Most common reasons:** Valve obstruction, tissue swelling in the throat (e.g. during radiotherapy).

**Measures:**

1. Clean the prosthesis with the Provox Brush and/or Flush. There may be food remnants increasing the airflow resistance.
2. If that does not help: Contact your clinician immediately.

**Symptoms:** Pain, heat, swelling, and rash (together or alone) in the area of the prosthesis or stoma.

**Most common reasons:** Tissue inflammation and infections.

**Measures:** Contact your clinician immediately.

**Symptoms:** Traces of blood are seen on the Brush after brushing.

**Most common reasons:** Tissue inflammation and infections at the esophageal side.

**Measures:** Contact your clinician immediately.

## 5. Additional information

### 5.1 Compatibility with MRI, X-ray and radiation therapy

The **Provox Vega** voice prosthesis can be left in the TE-puncture during the MRI, X-ray and radiation examination/therapy session. The Provox Vega voice prosthesis is compatible with Magnetic Resonance Imaging up to 3 Tesla, X-ray and radiation therapy up to 70 Gy. Note that the radio-opaque valve seat is visible on X-ray.

### 5.2 Device lifetime

Depending on individual biological circumstances the device life varies, and it is not possible to predict the integrity of the device over a longer period of time. The material of the device will be affected by e.g. bacteria and yeast, and the structural integrity of the device will eventually deteriorate.

### 5.3 Disposal

Always follow medical practice and national requirements regarding biohazards when disposing of a used medical device.

## 6. Product model

Model	Specification
8140-18	Provox Vega Puncture Set 17Fr 8mm
8141-18	Provox Vega Puncture Set 17Fr 10mm
8142-18	Provox Vega Puncture Set 17Fr 12.5mm
8143-18	Provox Vega Puncture Set 17Fr 15mm
8144-18	Provox Vega Puncture Set 20Fr 8mm
8145-18	Provox Vega Puncture Set 20Fr 10mm
8146-18	Provox Vega Puncture Set 20Fr 12.5mm
8147-18	Provox Vega Puncture Set 22.5Fr 8mm
8148-18	Provox Vega Puncture Set 22.5Fr 10mm
8149-18	Provox Vega Puncture Set 22.5Fr 12.5mm

## 7. Storage conditions

Store the product dry and away from sunlight at room temperature. Excursions permitted between 2°C - 42°C.

## 8. Reporting

Please note that any serious incident that has occurred in relation to the device shall be reported to the manufacturer and the national authority of the country in which the user and/or patient resides.

## 9. Legal Agent and After-sales service information

Coloplast (China) Medical Devices Ltd.  
Address: Unit1301-1306, 13th Floor, Building 1, No.5  
Lido Huayuan Road, Chaoyang District,  
Beijing

Agent contact information:  
Tel: 010-5920 1888  
Fax: 010-5920 1898  
Coloplast Customer Service Hotline  
Hotline: 400 700 7668  
Website: www.coloplast.com.cn

## 10. Production date and validity

Please see the label for the production date; the shelf life of product is 5 years.

## 11. Registration certificate number of medical devices

Certificate number of medical devices: 国械注进20223130609

## 12. Technical requirements for medical devices

Technical requirement number for medical devices: 国械注进20223130609

## 13. Edition of Instruction for Use

Article number: 11659, Edition date: 2026-03-19

## 14. Registration and Manufacturer company

Atos Medical AB  
Registration & Manufacturer location: Kraftgatan 8, SE-242 35 Hörby, Sweden  
Registration & Manufacturer contact: +46 (0)415 198 00 • info@atosmedical.com  
Production location: Kraftgatan 8, SE-242 35 Hörby, Sweden  
Country of origin: Sweden

## 造口气道管理

### 紧急情况

紧急医护人员要清楚知道您是依靠颈部造口呼吸的患者，这一点很重要。这将帮助他们做出正确的判断，将氧气和人工呼吸应用到造口上，而不是口或鼻子上。

我们建议您和您的医生从 [www.atosmedical.com/rescuebreathing](http://www.atosmedical.com/rescuebreathing) 下载人工呼吸指南。

### 可选择的情况

如果您需要接受插管手术（在气管中插入一根呼吸管），进行手术的麻醉师和医生要了解您是依靠颈部造口呼吸的患者并正在使用辅助发音管，这一点非常重要。重要的是他们要清楚明白辅助发音管应保持原本的位置。如果辅助发音管被移除，液体可能会从您的嘴、食管或胃进入气管。

在插入和拔出插管时要小心操作，不要让辅助发音管移位或脱出，这一点非常重要。

## 1. 术语表

医生	专业医疗人员或已取得相关执照的言语和语言治疗师 / 病理学家或受过发音重建程序训练的临床专科护士。
HME	热湿交换器（人工鼻）。此器械会保留呼出空气中的热量和水分，否则它们会因经由气管造口呼吸时而消失。
PE 段	咽食管段。指使用辅助发音管时，通过组织振动而产生声音的食道部位。
硅胶	一种在医疗器械中常用的材料。
气管食道穿刺口	在气管与食道之间建立的小型人工开口。
气管造口	在颈部正面，也就是气管连接至皮肤之处的呼吸开口（也称为“造口”）。
辅助发音管	一种插入气管食道穿刺口的带有固定轮缘的单向阀，通过重新导引空气至食道而能说话，同时降低食物和液体进入气管的风险。

## 2. 描述性信息

### 2.1 适用范围

该产品在食管与气管间建立单向气流通道，用于手术去除喉头（喉切除术）患者的发音重建。

### 2.2 结构及组成

辅助发音管由硅胶、聚偏二氟乙烯（PVDF）、有机硅粘合剂组成。其穿刺套装中的输送系统由甲基丙烯酸甲酯（MABS）、不锈钢、聚酰胺（PA66）和环氧胶、热塑性苯乙烯-乙烯/丁烯-苯乙烯（TPS-SEBS）、聚丙烯（PP）、聚偏二氟乙烯（PVDF）组成，其替换套装中的推置系统由聚丙烯（PP）、着色剂和聚丙烯（PP）、硅油组成。其附件冲洗器由硅胶、聚丙烯（PP）、蓝色母粒组成；塞子由硅胶组成。辅助发音管及其套装为环氧乙烷灭菌，一次性使用。附件为非灭菌。包装灭菌有效期为 5 年。

### 2.3 器械说明

Provox Vega 辅助发音管是单次使用的医疗器械，其单向阀让气管食道穿刺口保持开启以便说话，同时降低食物和液体进入气管的风险。该器械由医用级硅胶和氟塑料制成。

图解说明请见图 1。

- 辅助发音管罩
- 辅助发音管轴
- 气管侧轮缘
- 不透射线氟塑料阀座
- 食管侧轮缘
- 阀瓣

Provox Vega 辅助发音管包装

Provox Vega 辅助发音管包装包含下列用户配件：

- 1 个尺寸符合辅助发音管设计的 Provox Brush（Provox 清洁刷），非无菌
- 1 本 Provox Brush（Provox 清洁刷）使用说明
- 1 本 Provox Vega 辅助发音管患者操作手册

### 2.4 禁忌症

在已使用辅助发音管发音重建的患者中，使用或更换 Provox Vega 辅助发音管并无任何已知的禁忌症。

## 2.5 警告

可能发生 Provox Vega 辅助发音管或 Provox 发音重建系统其他组件的**意外吸入**（进入气管）。即时症状可能包括哽噎、咳嗽、窒息或喘鸣。若发生上述情况，**请立即就医治疗**。气管中的异物可能导致严重的并发症，例如急性呼吸窘迫和 / 或呼吸骤停，必须由医生移除异物。

可能会发生 Provox Vega 辅助发音管的**意外吞入**。若发生此情况，请与医生联系，以取得进一步的建议。

重复使用和重复加工处理可导致交叉污染和器械损坏，并可能因此而对患者造成伤害。

## 2.6 注意事项

若发生下列情况，请咨询医生：

- 辅助发音管内或其周围有渗漏（咳嗽和 / 或粘液颜色改变）
- 说话困难（更为费力和 / 或声音听起来更为紧张）
- 在穿刺部位出现发炎或组织变化的迹象（疼痛、发热、肿胀、刷牙后刷子留有血迹）。

为降低感染风险：

双手接触气管造口部位及清洁辅助发音管和 / 或配件之前，请确保双手已彻底清洁及干燥。

所有置入或接触气管造口与辅助发音管的器械都必须保持清洁。

为降低产品损坏风险：

仅可使用适用于 Provox Vega 辅助发音管的原厂 Provox 配件处理和清洁辅助发音管。

## 3. 使用说明

### 3.1 使用 Provox Vega 辅助发音管说话

关闭气管造口时，可将肺部的空气经由辅助发音管导向食道（图 2）。

气流会引起食道内的组织振动，从而产生声音。您可使用 Provox HME 等热湿交换器、使用 Provox FreeHands HME 等免持说话器械或仅以手指直接关闭造口来说话。

热湿交换器可以改善肺部功能，也会促进造口闭塞和说话。免持器械可以直接说话，而无需以手指关闭气管造口。

### 3.2 清洁 Provox Vega 辅助发音管

为让您用辅助发音管说话，此辅助发音管需要清洁以使空气能够通过。定期清洁辅助发音管也有助于延长器械寿命。

- 每天使用 Provox 清洁刷刷洗两次辅助发音管可清除辅助发音管上的粘液和食物残渣。
- 使用 Provox 冲洗器冲洗辅助发音管也可清除辅助发音管上的残留物和粘液，从而有助于延长器械寿命。  
**注：**Provox 冲洗器仅适合经医生评估能够在不需要医生监督的情况下始终遵循使用说明书的患者使用。
- 部分饮食措施，例如每天摄取含有乳酸菌的乳酪或酸奶，被视为有助于抵抗念珠菌过度生长。

**注意：**仅可使用适用于 Provox Vega 辅助发音管的原厂 Provox 配件清洁辅助发音管。其他器械可能会导致人身伤害或损坏辅助发音管。

### 3.3 配件

**Provox Brush**（清洁刷）是供患者清洁辅助发音管内侧使用（图 3）。

**Provox Flush**（冲洗器）是一种附加的清洁器械，用来冲洗辅助发音管（图 4）。

**Provox Vega Plug**（塞子）是患者使用的急救工具，可以暂时堵塞辅助发音管渗漏（图 5）。

### 3.4 附加器械

**Provox HME：**热湿交换器，可部分恢复已丧失的鼻部功能（加温、加湿、呼吸阻力）。

**Provox FreeHands HME：**结合自动气管造口阀的热湿交换器，旨在进行免持器械说话。

**Provox LaryTube：**硅胶气管插管，用于支持萎缩的造口，同时保留 Provox 系统的其他重建器械。

**Provox LaryButton：**自留式软硅胶气管插管，用于支持萎缩的造口，同时保留 Provox 系统的其他重建器械。

## 4. 不良事件 / 症状故障排除

医生有责任告知您辅助发音管重建的风险与益处，如果遭遇不良事件，应指导您采取何种措施。若您不确定是否已完全了解所有说明，请咨询医生，取得进一步说明。

**症状:** 辅助发音管置于原来的位置时会咳嗽（因饮食引起）。

**最常见原因:** 辅助发音管本身或周围渗漏。

**措施:**

1. 用 Provox 清洁刷和 / 或 Provox 冲洗器清洁辅助发音管。可能有食物残渣，以致阀无法正确关闭。

**若渗漏情况持续发生:**

2. 饮水时观察辅助发音管的情况。尝试确认辅助发音管的渗漏部位是在中央还是周围。
  - a.) 若您认为是中央部位渗漏，则可于饮食时使用 Provox Vega Plug 塞子，以避免渗漏。请通知医生您需要新的辅助发音管。
  - b.) 若您认为是周围部位渗漏，或者 Provox Vega Plug 塞子无法停止渗漏。请通知医生辅助发音管周围可能有渗漏。

**症状:** 说话变的越来越困难。

**最常见原因:** 阀阻塞、喉部组织肿胀（例如进行放射治疗时）。

**措施:**

1. 用 Provox Brush(清洁刷) 和 / 或 Provox Flush(冲洗器) 清洁辅助发音管。可能因为食物残渣增加了气流阻力。
2. 如果不起作用：请立即与医生联系。

**症状:** 辅助发音管或造口部位产生疼痛、发热、肿胀、皮疹(同时发生或单独发生)。

**最常见原因:** 组织发炎和感染。

**措施:** 请立即与医生联系。

**症状:** 刷洗后刷子上有血迹。

**最常见原因:** 辅助发音管食道侧发生组织发炎和感染。

**措施:** 请立即与医生联系。

## 5. 其他信息

### 5.1 与 MRI、X 射线和放射治疗的相容性

在进行 MRI、X 射线及放射检查 / 治疗期间，**Provox Vega** 辅助发音管可留在气管食道穿刺口中。Provox Vega 辅助发音管与最高 1.5 T 的核磁共振成像、最高 70 Gy 的 X 射线及放射治疗相容。请注意，不透射线的阀座在 X 射线中可见。

### 5.2 器械寿命

器械寿命因个人生理情况而异，并且不可能预测器械在使用较长时间后的完整性。器械的材质将受细菌和酵母等的影响，而其结构完整性终将降低。

### 5.3 弃置

弃置使用过的医疗器械时，请务必遵循生物危害相关的医疗惯例和国家要求。

## 6. 产品型号

型号	规格
8140-18	Provox Vega Puncture Set 17Fr 8 mm
8141-18	Provox Vega Puncture Set 17Fr 10 mm
8142-18	Provox Vega Puncture Set 17Fr 12.5 mm
8143-18	Provox Vega Puncture Set 17Fr 15 mm
8144-18	Provox Vega Puncture Set 20Fr 8 mm
8145-18	Provox Vega Puncture Set 20Fr 10 mm
8146-18	Provox Vega Puncture Set 20Fr 12.5 mm
8147-18	Provox Vega Puncture Set 22.5Fr 8 mm
8148-18	Provox Vega Puncture Set 22.5Fr 10 mm
8149-18	Provox Vega Puncture Set 22.5Fr 12.5 mm

## 7. 储存条件

在室温下储存产品，且存放于阴凉干燥处。温度偏差介于 2°C 至 42°C 之间。

## 8. 报告

请注意，发生任何与设备有关的严重事故时，应向制造商以及用户和 / 或患者所在国家 / 地区的主管部门报告。

## 9. 中国大陆地区代理人及售后服务机构

代理人名称 / 售后服务单位：康乐保（中国）医疗用品有限公司  
代理人住所：北京市朝阳区丽都花园路 5 号院 1 号楼 13 层 1301-1306 单元  
代理人联系方式：  
电话：010-5920 1888  
传真：010-5920 1898  
康乐保客户服务热线  
热线电话：400 700 7668  
网址：www.coloplast.com.cn

## 10. 生产日期和使用期限

请参阅标签了解生产日期；产品的有效期为 5 年。

## 11. 医疗器械注册证编号

注册证编号：国械注进 20223130609

## 12. 医疗器械技术要求编号

产品技术要求编号：国械注进 20223130609

## 13. 说明书版本号

说明书版本编号：11659，说明书修订日期：2026/3/19

## 14. 生产企业和注册人

注册人名称 / 生产企业名称：欧拓适医疗有限责任公司 Atos Medical AB  
注册人住所 / 生产企业住所：Kraftgatan 8, SE-242 35 Hörby, Sweden  
注册人联系方式 / 生产企业联系方式：  
+46 (0)415 198 00 · info@atosmedical.com  
生产地址：Kraftgatan 8, SE-242 35 Hörby, Sweden  
原产地：瑞典

## 符号的解释



Manufacturer; 制造商



Date of manufacture; 生产日期



Use-by date; 使用期限



Batch code; 批次代码



Product reference number; 产品编号



Do not re-use; 不得二次使用



Sterilized using ethylene oxide; 经环氧乙烷灭菌



Do not use if package is damaged; 包装破损切勿使用



Keep away from sunlight and keep dry; 怕雨, 怕晒



Storage temperature limit; 储存温度限制



Store at room temperature. Temporary deviations within the temperature range (max-min) are allowed; 室温下存放。允许温度范围内(最高-最低)的暂时偏差



Caution, consult instructions for use; 警告, 参阅使用说明书



Instructions for use; 使用说明书

**MD**

Medical Device; 医疗器械



Instructions for use intended for clinician; 临床医生使用说明书



Instructions for use intended for patient; 患者使用说明书

**Rx**  
**ONLY**

Prescription; 凭处方购买 (仅适用于美国)



11659\_03  
2026-03-19

**Atos**  
atosmedical.com



Atos Medical AB  
Kraftgatan 8, SE-242 35 Hörby, Sweden  
Tel: +46 (0)415 198 00 • [info@atosmedical.com](mailto:info@atosmedical.com)

Atos and the Atos logo are trademarks of Coloplast A/S.  
© 2026 Coloplast A/S. All rights reserved.